

# CME-850X



## Specifications

### Power

Cummins QSB5.9-30-TAA turbocharged and charge air cooled 6 cylinder Tier 2 U.S. EPA emissions certified diesel engine  
Rated horsepower (driving).....185 hp @ 2500 rpm  
Rated horsepower (drilling).....110 hp @ 2500 rpm

### Carrier

Track width.....33 in. (84 cm)  
Tractive force (max).....45,800 lbs. (20,793 kg)  
Average ground bearing pressure.....2.9 psi (.204 kgf/cm)  
Inside turning radius.....in place  
Drive: hydrostatic closed-loop transmissions consisting of variable displacement piston pump, two-speed bent-axis piston motor, and double reduction planetary wheel drive  
Hydraulic front winch.....15,000 lb. (6,810 kg)

### Speed (max)

Low range.....2 mph (3.22 kph)  
High range.....8 mph (12.87 kph)

### Gradeability

Straight-ahead climb.....60% grade  
Side-hill traverse.....40% grade

### Rotary Drive

Transmission.....5 speed fwd., 1 speed rev.  
Rotary torque.....15,100 ft. lbs. max (20,535 Nm)  
Rotary speed.....600 rpm max  
Hollow spindle I.D. 2 3/4 in. (7 cm) (3 3/4 in. (10 cm) avail.)

### Hydraulic Feed System

Retract force.....28,275 lbs. (12,826 kg)  
Pull-down force.....18,650 lbs. (8,460 kg)  
Retract rate (max).....90 ft. (27 m)/min.  
Feed rate (max).....58 ft. (18 m)/min.  
Stroke.....72 in. (183 cm)

### Leveling System

Three jacks, inverted design with chrome-plated piston rods enclosed at all times  
Stroke.....36 in. (91 cm)

### Approximate Weight

(less drilling tools).....26,000 lbs. (11,804 kg)

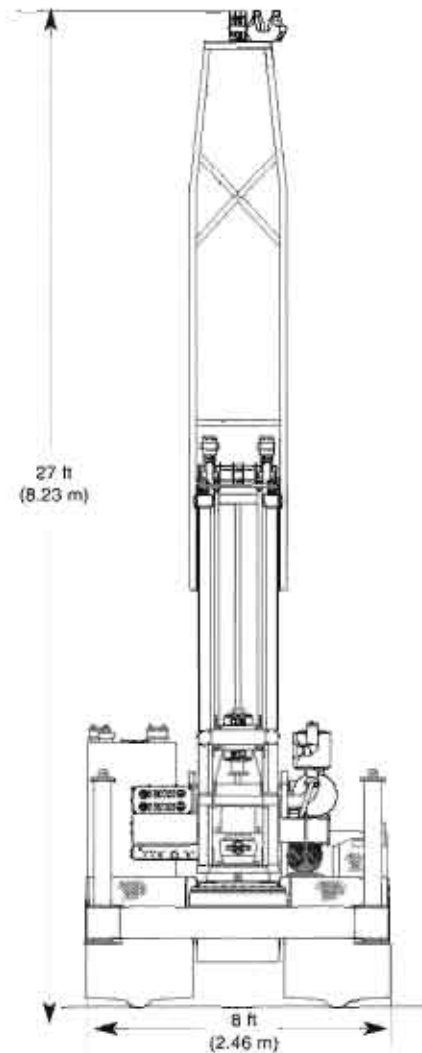
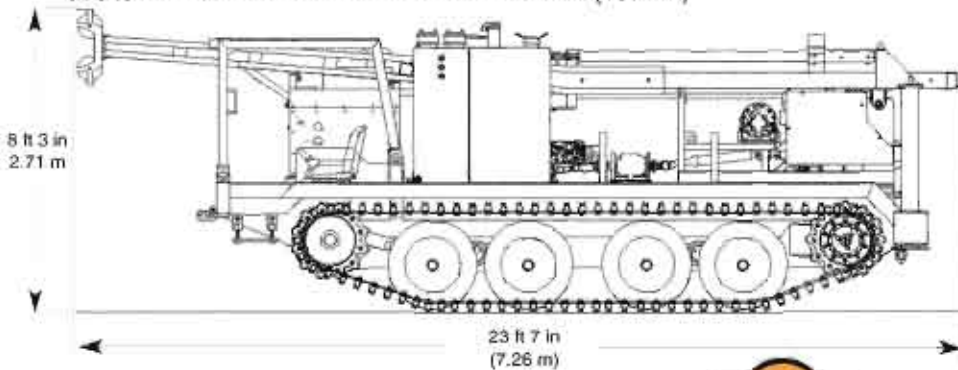

**CENTRAL MINE EQUIPMENT COMPANY**  
4215 Rider Trail North, Earth City (St. Louis), Missouri, 63045 USA  
Phone: 314-291-7700 • 1-800-325-8827 • FAX: 314-291-4880  
E-mail: info@cmeco.com • Website: www.cmeco.com

Performance ratings are based on engineering specifications, calculations and accepted industry standards. Capacities may vary according to drilling conditions. CME reserves the right to amend these specifications at any time, without notice.  
MKT 850 103 294 9/05



# CME-850X





# Mobility without compromise

**The CME-850X can get you to locations other people consider inaccessible.**

## **Low ground bearing pressure + high tractive power = maximum mobility**

33 inch wide tracks spread the surface contact area of this all-terrain track drill over more than 9,650 square inches. Ground bearing pressure is only 2.9 psi. That's less than the average man's footstep. The CME-850X can go places you can't even walk. The high flotation allows you to negotiate soft mud, deep snow or sand. And, the walking beam suspension easily climbs over rocks and fallen logs.

The bottom line is, you won't have to spend valuable time and money clearing accesses or building roads to get to inaccessible drill sites.



## **Integral design means no compromise**

Since we designed the carrier and track-drive system ourselves, they are an integral part of the overall machine.

We made sure that weight is evenly distributed between front and rear. We also kept the center of gravity as low as possible. That's why the CME-850X has such exceptional balance and stability.

The hydrostatic track drive motors are located in the rear of the carrier so that the drive sprockets pull the tracks under the carrier. This ensures that the tracks are kept tight at the bottom, where they contact the ground, further improving traction.

## **Completely self-contained drilling unit**

Just getting a drill to a tough location is not enough. That's why we designed the deck layout to provide plenty of storage area for augers, rods and other drilling tools. The CME-850X can carry everything you need to get the job done, right on board.

## **Shift "on the fly" for better control**

Each track is independently driven by a hydrostatic transmission circuit for dependable trouble-free operation. The two-speed drive motors provide maximum pulling power up to 2 mph in low range and speeds of up to 8 mph in high range. The drive motors can be shifted "on the fly" from low to high range without stopping which is advantageous when climbing or descending grades.

## **Precise steering provides agility**

The independent hydrostatic track drive allows you to counter rotate the tracks and turn in place so you can easily maneuver around or between those objects which you can't go over.

Steering is accomplished by two joystick controllers, one for each track, conveniently located adjacent to the operator. The joysticks provide smooth, positive control for precise mobility. A rocker switch on the top of each joystick controls engine speed.

## **Protective belly pan**

The underside of the CME-850X is protected by a steel belly pan. It not only reduces the possibility of damage to rig components, but also acts as a skid when moving through soft mud or snow. There are no protrusions under the carrier to hang up on logs or rocks.

## **ROPS protection**

A roll-over protective structure is standard on the CME-850X. It meets SAE specification J1040C and includes a front brush guard with kick-out provision.

## **8 foot width is over-the-road legal**

You won't have to waste time getting expensive over-width permits to transport the CME-850X. It's only 8 feet wide. That also means you won't be restricted to certain days and hours when transporting it to a location.



# Optional equipment for even more versatility and productivity

## Hydraulic rod holder and breakout wrench\*

The hydraulic rod holder makes your job quicker and safer. It not only pivots from on-hole to off-hole positions, but also hydraulically moves in and out. That's what makes it so compatible with the in-out /sideways slide bases.



## Quick mast disconnect

This feature allows you to quickly disconnect the mast when working inside buildings, underneath bridges or in other low overhead drilling locations. Since the mast is completely separated from the uprights, it doesn't interfere with other drill functions such as the in-out slide bases.

With the mast in a horizontal position, you simply clamp the mast to its storage rack and extend the drill's in-out slide base. This pulls the sockets on the upright drill frame away from the large tapered pins on the mast.



## Automatic hammer\*

Our 140-pound automatic hammer gives you extremely consistent and accurate Standard Penetration Test results, meeting all ASTM-D-1586-84 requirements. That's because there are no ropes or cables to impede the free-fall of the weight.

The hammer swings from the stored position to on-hole position. Since raising and lowering is done hydraulically, set-up is quick and almost effortless.

To improve safety, all moving parts are enclosed, including the impact area between weight and anvil. A 340-pound hammer is also available.



## All-weather cab - ROPS certified

For severe weather conditions, the CME-850X can be equipped with an all-weather ROPS cab. This cab is insulated and includes such features as an efficient heater, a defroster, a sliding left window and a windshield wiper.





# vity

## Additional optional equipment

- High speed rotation
- Underside sheave
- Low clearance sheave
- Cathead, 8 in. diameter 1,370 lbs. capacity  
speed.....710 ft. per min.
- 8500 lb. hydraulic hoist  
max line speed: 72 ft./min. up—310 ft./min. dwn
- 3200 lb. hydraulic hoist  
max line speed...100 ft./min.
- 1800 lb. hydraulic hoist  
max line speed...200 ft./min.
- Hydraulic wireline hoist (1,800 lb. pull)  
max line speed...200 ft./min.
- Auger and rod guides for angle drilling
- Drill rod chuck
- Fluted kelly and chuck assembly
- Spindle adapter
- Water pumps:
  - Moyno progressive cavity... 36 gpm/225 psi
  - Moyno progressive cavity... 84 gpm/225 psi
  - FMC Triplex..... 25 gpm/500 psi
  - FMC Triplex..... 40 gpm/800 psi
- 140 gallon water tank
- Additional tool storage compartments
- Continuous Sample Tube System



Cathead



FMC Triplex  
40 gpm/800 psi  
water pump



140 gallon water tank



Fluted kelly and chuck  
assembly



8500 lb. hoist

# Drilling Performance without compromise



Once you get to the site, you have all the power and versatility you need for auger, rotary, or core drilling applications

## Hydraulic feed and retract system provides 28,275 lbs. of retract force and 18,650 lbs. of down pressure

The hydraulic vertical drive system has no chains or cables which can stretch. It gives you precise control of force on the drilling tools.

For exceptional drilling efficiency, the feed system has two separate controls. One gives you manual control of feed and retract and features both normal and fast retract positions. Retract rates of up to 90 feet per minute let you add or remove drilling tools quickly.

The other is used exclusively for feed and has a detent engaged position.

Flow and pressure controls let you dial in specific feed rate and feed pressure.

This system is extremely advantageous in core drilling and other operations that require precise control of feed.

And since the two controls are isolated, you can use the manual control for rapid retract without changing pressure settings for the detent feed control.

The distance from the sheaves to the ground is 26 ft. That means you can hoist 20 ft. of rods or augers with clearance to spare. When equipped with three hoists, the CME-850X can pull 60 ft. of rods or augers without having to lay any down on the ground.

## Control logic - the key to operator productivity

Drilling and set-up controls are logically arranged on a control panel located at the driller's station. For added convenience, we've staggered the more frequently used controls, such as the hydraulic hoists and sliding base levers.

## Dependable mechanical rotary drive provides 15,100 ft. lbs. of rotary torque, plus high rotation speed when you need it

You get the torque you need for auger drilling up to 15-inch holes, as well as rotation speeds over 700 rpm for rotary or core drilling applications. With five forward gears and one reverse, there's a rotation speed and torque combination available for just about any situation. The rotary drive transmission is driven through a torque converter that provides shock overload protection.

## Patented spindle brake stops rotation in an instant

An emergency spindle brake stops rotation instantaneously. This system is activated by two conveniently located push button switches as well as by strategically located wobble switches.



## Slide bases make the job easier and quicker

The drill is mounted to the carrier on hydraulically actuated sliding bases. A 15-inch in-out movement allows you to quickly move the drill off the borehole and align the sheaves for lifting tools with the cathead or any of the hoists.

A six-inch sideways movement gives you even more versatility. Aligning augers or rods when making connections is easy. Or, if the bit drifts off at an angle when you start an auger hole, you can quickly straighten it to a vertical position.

If you've ever tried to line up your rig on an existing bore hole, you've probably already recognized another benefit of the slide bases.

## Patented angle drilling system for special drilling applications

This unique system is especially effective for drilling underneath ponds, storage tanks or other structures. When used with our patented Continuous Sample Tube System, you can even take soil samples while drilling angle holes.

The angle drilling system will also allow you to drill vertically with the carrier positioned on an uphill slope. That can eliminate the time-consuming job of leveling an area on which to place the rig.

And, since the kelly drive is directly connected to the right angle drive box, you can raise or lower the mast with the drivetrain already connected and ready to go.

